

Picture Hanging Tips

You have invested in a special framing project to display, enjoy, and preserve your memories. Now you need to choose a special location in your home to hang it. There are several things you need to consider as you begin to make your decision. Here are some basic tips:

1. Lay your wall out on paper or at least develop a mental plan before you begin.
2. Hang in groupings if possible, and consider the décor themes of the room.
3. Avoid hanging pictures directly in front of windows.
4. Avoid hanging pictures directly in front of or behind doors.
5. Avoid hanging pictures directly over or under vents or heat ducts.
6. Avoid hanging pictures in basements, bathrooms, or any other areas where extremely high humidity levels might be a problem.
7. Make sure you support your frame properly (get an approximate weight and use a hanging device that is rated accordingly).
 - a. If using a wire be sure to support the wire at two points to reduce the stress in the wire and on the frame. (See Fig. 1 and Fig. 2 below)
8. If you are in a high traffic area or have children who are prone to knock things off the wall, ask your framer to install security hangers on your project to protect both the frame package and those who are nearby.
9. Consider the lighting. If you need special lighting to showcase or accent your work, ask your framer or home décor specialist for suggestions and ideas.
10. Double Check all measurements before installing hangers in the wall, and use a level and/or laser to ensure the project hangs at the appropriate angle.

Fig. 1

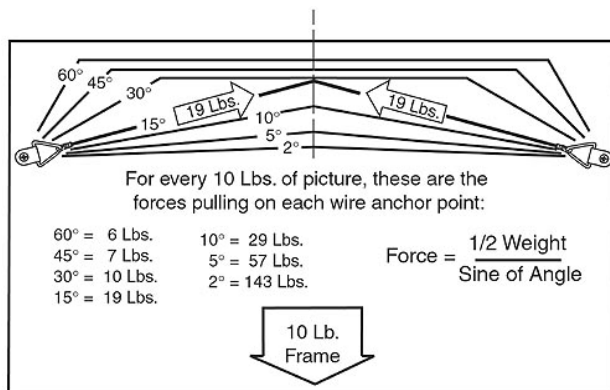
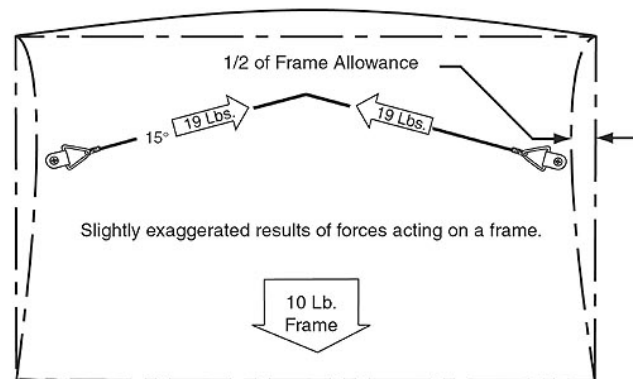

Fig. 2



Framing Excellence
3622 Houston Street
Lithia Springs, GA 30122
(770)948-8884
WWW.EXCELLENTFRAMES.COM